

LG290P (03)

Hardware Design

GNSS Module Series

Version: 1.1

Date: 2024-12-30

Status: Released



At Quectel, our aim is to provide timely and comprehensive services to our customers. If you require any assistance, please contact our headquarters:

Quectel Wireless Solutions Co., Ltd.

Building 5, Shanghai Business Park Phase III (Area B), No.1016 Tianlin Road, Minhang District, Shanghai 200233, China

Tel: +86 21 5108 6236

Email: info@quectel.com

Or our local offices. For more information, please visit:

<http://www.quectel.com/support/sales.htm>.

For technical support, or to report documentation errors, please visit:

<http://www.quectel.com/support/technical.htm>.

Or email us at: support@quectel.com.

Legal Notices

We offer information as a service to you. The provided information is based on your requirements and we make every effort to ensure its quality. You agree that you are responsible for using independent analysis and evaluation in designing intended products, and we provide reference designs for illustrative purposes only. Before using any hardware, software or service guided by this document, please read this notice carefully. Even though we employ commercially reasonable efforts to provide the best possible experience, you hereby acknowledge and agree that this document and related services hereunder are provided to you on an “as available” basis. We may revise or restate this document from time to time at our sole discretion without any prior notice to you.

Use and Disclosure Restrictions

License Agreements

Documents and information provided by us shall be kept confidential, unless specific permission is granted. They shall not be accessed or used for any purpose except as expressly provided herein.

Copyright

Our and third-party products hereunder may contain copyrighted material. Such copyrighted material shall not be copied, reproduced, distributed, merged, published, translated, or modified without prior written consent. We and the third party have exclusive rights over copyrighted material. No license shall be granted or conveyed under any patents, copyrights, trademarks, or service mark rights. To avoid ambiguities, purchasing in any form cannot be deemed as granting a license other than the normal non-exclusive, royalty-free license to use the material. We reserve the right to take legal action for noncompliance with abovementioned requirements, unauthorized use, or other illegal or malicious use of the material.

Trademarks

Except as otherwise set forth herein, nothing in this document shall be construed as conferring any rights to use any trademark, trade name or name, abbreviation, or counterfeit product thereof owned by Quectel or any third party in advertising, publicity, or other aspects.

Third-Party Rights

This document may refer to hardware, software and/or documentation owned by one or more third parties (“third-party materials”). Use of such third-party materials shall be governed by all restrictions and obligations applicable thereto.

We make no warranty or representation, either express or implied, regarding the third-party materials, including but not limited to any implied or statutory, warranties of merchantability or fitness for a particular purpose, quiet enjoyment, system integration, information accuracy, and non-infringement of any third-party intellectual property rights with regard to the licensed technology or use thereof. Nothing herein constitutes a representation or warranty by us to either develop, enhance, modify, distribute, market, sell, offer for sale, or otherwise maintain production of any our products or any other hardware, software, device, tool, information, or product. We moreover disclaim any and all warranties arising from the course of dealing or usage of trade.

Privacy Policy

To implement module functionality, certain device data are uploaded to Quectel’s or third-party’s servers, including carriers, chipset suppliers or customer-designated servers. Quectel, strictly abiding by the relevant laws and regulations, shall retain, use, disclose or otherwise process relevant data for the purpose of performing the service only or as permitted by applicable laws. Before data interaction with third parties, please be informed of their privacy and data security policy.

Disclaimer

- a) We acknowledge no liability for any injury or damage arising from the reliance upon the information.
- b) We shall bear no liability resulting from any inaccuracies or omissions, or from the use of the information contained herein.
- c) While we have made every effort to ensure that the functions and features under development are free from errors, it is possible that they could contain errors, inaccuracies, and omissions. Unless otherwise provided by valid agreement, we make no warranties of any kind, either implied or express, and exclude all liability for any loss or damage suffered in connection with the use of features and functions under development, to the maximum extent permitted by law, regardless of whether such loss or damage may have been foreseeable.
- d) We are not responsible for the accessibility, safety, accuracy, availability, legality, or completeness of information, advertising, commercial offers, products, services, and materials on third-party websites and third-party resources.

Copyright © Quectel Wireless Solutions Co., Ltd. 2024. All rights reserved.

Safety Information

The following safety precautions must be observed during all phases of operation, such as usage, service, or repair of any terminal or mobile incorporating the module. Manufacturers of the terminal should notify users and operating personnel of the following safety precautions by incorporating them into all product manuals. Otherwise, Quectel assumes no liability for customers' failure to comply with these precautions.



Ensure that the product may be used in the country and the required environment, as well as that it conforms to the local safety and environmental regulations.



Keep away from explosive and flammable materials. The use of electronic products in extreme power supply conditions and locations with potentially explosive atmospheres may cause fire and explosion accidents.



The product must be powered by a stable voltage source, and the wiring shall conform to security precautions and fire prevention regulations.



Proper ESD handling procedures must be followed throughout the mounting, handling and operation of any devices and equipment that incorporate the module to avoid ESD damages.

About the Document

Document Information	
Title	LG290P (03) Hardware Design
Subtitle	GNSS Module Series
Document Type	Hardware Design
Document Status	Released

Revision History

Version	Date	Description
-	2023-11-30	Creation of the document
1.0	2024-08-21	First official release
1.1	2024-12-30	<ol style="list-style-type: none"> Updated the voltage range of VCC (Table 2, Table 6 and Table 10). Updated the test condition for power consumption, TTFF (without AGNSS), accuracy of 1PPS signal, velocity accuracy and dynamic performance; and updated the accuracy of 1PPS signal to 1σ value (Table 3). Updated the supported baud rates and added internal pull-up and pull-down design of UART1–UART3 (Chapters 4.1.1.1 to 4.1.1.3). Updated the I2C interface feature from open drain output to using a built-in 2.2 kΩ pull-up resistor (Chapter 4.1.1.4). Moved information related to antenna selection guide to <code>Quectel_GNSS_Antenna_Application_Note</code>. Added the note on the measured supply current values and updated the test condition for the typical and peak values of supply current (Chapter 6.3). Updated the module coplanarity requirement (Chapter 7.1). Updated the pre-baking time to 24 h (Chapter 8.2). Updated the reference document for recommended module stencil

Version	Date	Description
		thickness (Chapter 8.3).

Contents

Safety Information..... 3

About the Document..... 4

Contents..... 6

Table Index..... 8

Figure Index..... 9

1 Product Description..... 10

 1.1. Overview..... 10

 1.1.1. Special Marks..... 11

 1.2. Features 11

 1.3. Performance..... 13

 1.4. Block Diagram 15

 1.5. GNSS Constellations and Frequency Bands..... 15

 1.6. Augmentation System 17

 1.6.1. SBAS..... 17

 1.7. AGNSS*..... 17

 1.8. RTK 17

 1.8.1. RTK Rover..... 18

 1.8.2. RTK Base Station..... 18

 1.9. Firmware Upgrade..... 18

2 Pin Assignment..... 19

3 Power Management 23

 3.1. Power Unit..... 23

 3.2. Power Supply 24

 3.2.1. VCC..... 24

 3.2.2. V_BCKP 24

 3.3. Power Modes 26

 3.3.1. Feature Comparison 26

 3.3.2. Continuous Mode 26

 3.3.3. Backup Mode 26

 3.4. Power-up Sequence..... 27

 3.5. Power-down Sequence 28

4 Application Interfaces 29

 4.1. I/O Pins..... 29

 4.1.1. Communication Interfaces 29

 4.1.1.1. UART1 Interface..... 29

 4.1.1.2. UART2 Interface..... 30

 4.1.1.3. UART3 Interface..... 31

 4.1.1.4. I2C Interface* 31

 4.1.2. RTK_STAT/ANT_ON*..... 32

4.1.3.	1PPS	32
4.2.	System Pins	33
4.2.1.	RESET_N.....	33
5	Design	34
5.1.	Antenna Specification	34
5.2.	Active Antenna Reference Design.....	35
5.3.	Recommended Footprint.....	36
6	Electrical Specification.....	37
6.1.	Absolute Maximum Ratings	37
6.2.	Recommended Operating Conditions.....	37
6.3.	Supply Current Requirement.....	38
6.4.	ESD Protection.....	39
7	Mechanical Dimensions	40
7.1.	Top, Side and Bottom View Dimensions	40
7.2.	Top and Bottom Views	41
8	Product Handling	42
8.1.	Packaging Specification	42
8.1.1.	Carrier Tape	42
8.1.2.	Plastic Reel	43
8.1.3.	Mounting Direction	43
8.1.4.	Packaging Process	44
8.2.	Storage.....	45
8.3.	Manufacturing and Soldering	46
9	Labelling Information	48
10	Appendix References	49

Table Index

Table 1: Special Marks.....	11
Table 2: Product Features.....	11
Table 3: Product Performance	13
Table 4: GNSS Constellations and Frequency Bands.....	16
Table 5: Parameter Definition	19
Table 6: Pin Description	20
Table 7: Feature Comparison in Different Power Modes	26
Table 8: Recommended Antenna Specifications.....	34
Table 9: Absolute Maximum Ratings	37
Table 10: Recommended Operating Conditions.....	38
Table 11: Supply Current	39
Table 12: Carrier Tape Dimension Table (Unit: mm).....	42
Table 13: Plastic Reel Dimension Table (Unit: mm).....	43
Table 14: Recommended Thermal Profile Parameters	46
Table 15: Related Documents.....	49
Table 16: Terms and Abbreviations.....	49

Figure Index

Figure 1: Block Diagram.....	15
Figure 2: RTK Operation	17
Figure 3: Pin Assignment	19
Figure 4: Internal Power Supply	23
Figure 5: VCC Input Reference Circuit	24
Figure 6: Backup Domain Input Reference Circuit	25
Figure 7: Reference Power Supply Circuit with 3.7 V Lithium Battery	25
Figure 8: Enter/Exit Backup Mode Sequence	27
Figure 9: Power-up Sequence	27
Figure 10: Power-down and Power-on Restart Sequence	28
Figure 11: UART1 Interface Reference Design	29
Figure 12: UART2 Interface Reference Design	30
Figure 13: UART3 Interface Reference Design	31
Figure 14: I2C Interface Reference Design	32
Figure 15: Reference OC Circuit for Module Reset	33
Figure 16: Reset Sequence	33
Figure 17: Active Antenna Reference Design.....	35
Figure 18: Recommended Footprint	36
Figure 19: Top, Side and Bottom View Dimensions	40
Figure 20: Top and Bottom Module Views.....	41
Figure 21: Carrier Tape Dimension Drawing (Unit: mm)	42
Figure 22: Plastic Reel Dimension Drawing.....	43
Figure 23: Mounting Direction	43
Figure 24: Packaging Process	44
Figure 25: Recommended Reflow Soldering Thermal Profile	46
Figure 26: Labelling Information.....	48

1 Product Description

1.1. Overview

The Quectel LG290P (03) module supports multiple global positioning and navigation systems: GPS, GLONASS, Galileo, BDS, QZSS and NavIC. The module also supports advanced satellite-based signals (PPP): PPP-B2b, QZSS L6 and Galileo HAS E6, and SBAS (including WAAS, EGNOS, BDSBAS, MSAS, GAGAN and SDCM) and AGNSS*.

Key features:

- Multi-constellation and quad-band GNSS module featuring a high-performance, high reliability positioning engine, which facilitates fast and precise GNSS positioning.
- Serial communication interfaces: UART and I2C*.
- LG290P (03) integrates an RTK position engine in order to provide centimeter level positioning accuracy in an open-sky environment.
- Standard RTCM correction inputs and centimeter level navigation using third-party base station RTCM data.
- The embedded flash memory provides the capacity for storing user-specific configurations and future firmware updates.

The Quectel LG290P (03) module is an SMD type module with a compact form factor of 12.2 mm × 16.0 mm × 2.6 mm. It can be embedded in your applications through the 79 LGA pins.

The module is fully compliant with the EU RoHS Directive.

1.1.1. Special Marks

Table 1: Special Marks

Mark	Definition
*	Unless otherwise specified, when an asterisk (*) is used after a function, feature, interface, pin name, or argument, it indicates that the function, feature, interface, pin, or argument is under development and currently not supported; and the asterisk (*) after a model indicates that the sample of the model is currently unavailable.
●	The symbol indicates that a function or technology is supported by the module(s).

1.2. Features

Table 2: Product Features

Features	LG290P (03)	
Grade	Industrial	●
	Automotive	-
Category	Standard Precision GNSS	-
	High Precision GNSS	●
	DR	-
	RTK	●
	Timing	-
VCC Voltage	3.0–3.6 V, Typ.: 3.3 V	●
V_BCKP Voltage	2.0–3.6 V, Typ.: 3.3 V	●
I/O Voltage	Following VCC	●
Communication Interfaces	UART	●
	SPI	-
	I2C*	●
	CAN	-

Features		LG290P (03)	
	USB	-	
Integrated Features	Additional LNA	-	
	Additional Filter	●	
	RTC Crystal	●	
	TCXO Oscillator	●	
	6-axis IMU	-	
	Number of Concurrent GNSS	5 + QZSS	
Constellations and Frequency Bands	GPS	L1 C/A	●
		L1C*	●
		L5	●
		L2C	●
	GLONASS	L1	●
		L2	●
	Galileo	E1	●
		E5a	●
		E5b	●
		E6	●
	BDS	B1I	●
		B1C	●
		B2a	●
		B2b	●
		B2I	●
		B3I	●
	QZSS	L1 C/A	●
L1C*		●	

Features	LG290P (03)	
	L5	●
	L2C	●
	NavIC	L5 ●
SBAS	L1	●
	PPP-B2b	●
PPP	QZSS L6	●
	Galileo HAS E6	●
Temperature Range	Operating Temperature Range: -40 °C to +85 °C Storage Temperature Range: -40 °C to +90 °C	
Physical Characteristics	Size: (12.2 +0.30/-0.15) mm × (16.0 +0.30/-0.15) mm × (2.6 ±0.20) mm Weight: Approx. 0.9 g	

NOTE

For more information about GNSS constellation configuration, see [document \[1\] protocol specification](#).

1.3. Performance

Table 3: Product Performance

Parameter	Specification	LG290P (03)
Power Consumption ¹ (GPS + GLONASS + Galileo + BDS + QZSS + NavIC)	Acquisition	99 mA (326.7 mW)
	Tracking	99 mA (326.7 mW)
	Backup Mode	12 μA (39.6 μW)
Sensitivity ²	Acquisition	-146 dBm

¹ Tested at room temperature, with typical operating voltage, and satellites signal of -130 dBm configured by the instrument.

² Tested with two external LNA with 18.5 dB gain and 0.85 dB noise figure (During the sensitivity test of tracking, ensure that there are no less than 12 satellites for GPS L1 and L5, 10 satellites for BDS B1I and B2a, and 10 satellites for Galileo E1 and E5a).

Parameter	Specification	LG290P (03)
(GPS + GLONASS + Galileo + BDS + QZSS + NavIC)	Reacquisition	-155 dBm
	Tracking	-160 dBm
TTFF ¹ (without AGNSS)	Cold Start	28 s
	Warm Start	28 s
	Hot Start	1.7 s
Horizontal Position Accuracy	Autonomous ³	0.7 m
	RTK ⁴	0.8 cm + 1 ppm
Vertical Accuracy	Autonomous ³	2.5 m
	RTK ⁴	1.5 cm + 1 ppm
Update Rate	Default	10 Hz
	Maximum	20 Hz
Convergence Time	RTK ⁴	5 s
Accuracy of 1PPS Signal ¹	1 σ	5 ns
Velocity Accuracy ¹	Without Aid	0.03 m/s
Dynamic Performance ¹	Maximum Altitude	10000 m
	Maximum Velocity	490 m/s
	Maximum Acceleration	4g

³ CEP; 50 %; 24 hours static; instrument configuration: GPS L1 + L5, Galileo E1 + E5a and BDS B1I + B2a; -130 dBm.

⁴ CEP, 50 %, with active high-precision antenna in an open-sky environment and within 1 km of the base station.

1.4. Block Diagram

A block diagram of the module is present below. It includes a front-end section with two additional SAW filters and a diplexer, a TCXO, a power splitter and an XTAL, a GNSS IC with internal PMU. The diplexer integrates a low-pass filter and a high-pass filter, which can improve the out-of-band rejection.

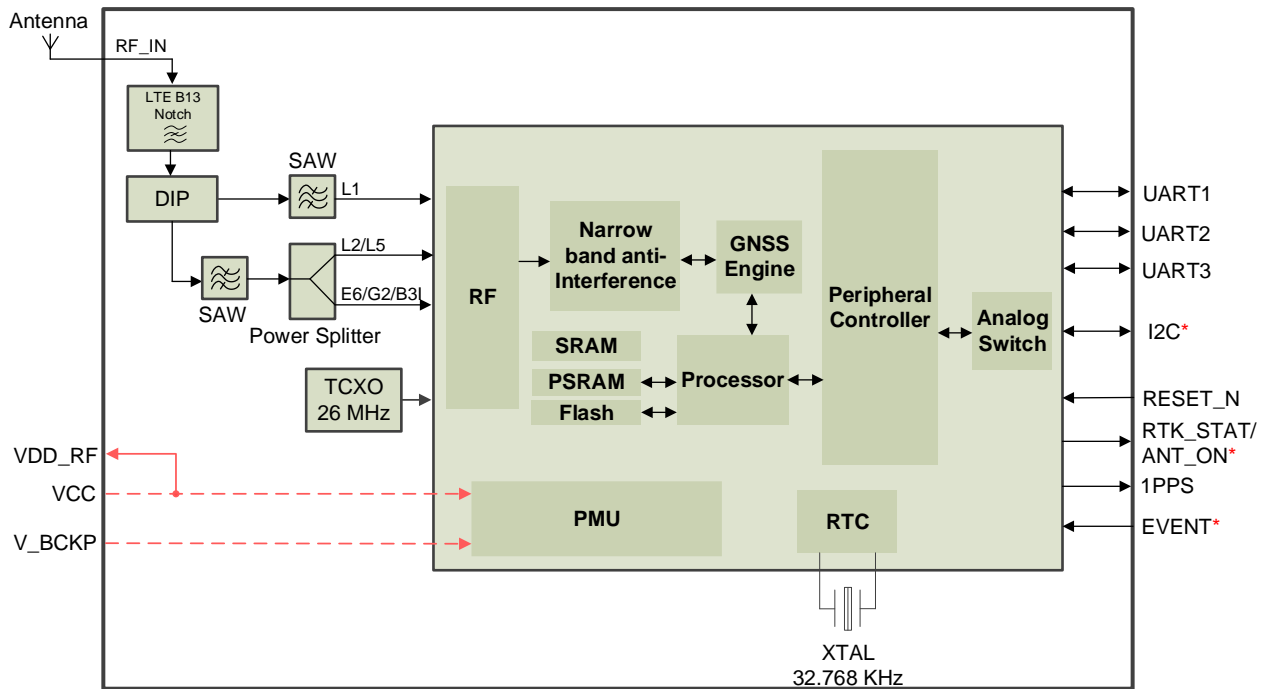

Figure 1: Block Diagram

1.5. GNSS Constellations and Frequency Bands

The module is a Quad-band GNSS receiver that can receive and track multiple GNSS systems. Due to the RF front-end architecture, it can track the following GNSS constellations: GPS, GLONASS, Galileo, BDS, QZSS, and NavIC, as well as SBAS satellites. In addition, the module also supports the advanced satellite-based signals (PPP): PPP-B2b, QZSS L6* and Galileo HAS E6 If low power consumption is a key factor, then the module can be configured for a subset of GNSS constellations.

QZSS is a regional navigation satellite system that transmits signals compatible with the GPS L1 C/A, L1C, L2C and L5 signals for the Pacific region covering Japan and Australia. The module can detect and track QZSS L1C*, L1 C/A, L2C and L5 signals concurrently with GPS signals, leading to better availability especially under challenging conditions, e.g., in urban canyons.

NavIC is a regional satellite navigation system that transmits additional L5 signals for complying with the requirements of an independent accurate positioning system for users in India. The module is designed to receive and track NavIC L5 signal centered on 1176.45 MHz.

Table 4: GNSS Constellations and Frequency Bands

System	Signals
GPS	L1 C/A: 1575.42 MHz L1C*: 1575.42 MHz L5: 1176.45 MHz L2C: 1227.6 MHz
GLONASS	L1: 1602 MHz + K × 562.5 kHz, K = (-7 to +6, integer) L2: 1245.78125 MHz
Galileo	E1: 1575.42 MHz E5a: 1176.45 MHz E5b: 1207.14 MHz E6: 1278.75 MHz
BDS	B1I: 1561.098 MHz B1C: 1575.42 MHz B2a: 1176.45 MHz B2b: 1207.14 MHz B2I: 1207.14 MHz B3I: 1268.52 MHz
QZSS	L1 C/A: 1575.42 MHz L1C*: 1575.42 MHz L5: 1176.45 MHz L2C: 1227.6 MHz
NavIC	L5: 1176.45 MHz
PPP-B2b	1207.14 MHz
QZSS L6	1278.75 MHz
Galileo HAS E6	1278.75 MHz

1.6. Augmentation System

1.6.1. SBAS

The module supports the reception of SBAS signals. By augmenting primary GNSS constellations with additional satellite-broadcast messages, the system improves the accuracy and reliability of GNSS information by correcting signal measurement errors and providing information about signal accuracy, integrity, continuity and availability. SBAS transmits signals for ranging or distance measurement, thus further improving availability. Supported SBAS systems: WAAS, EGNOS, BDSBAS, MSAS, GAGAN and SDCM.

1.7. AGNSS*

The module supports the AGNSS feature that significantly reduces the module’s TTFF, especially under lower signal conditions. To implement the AGNSS feature, the module should get the assistance data including the current time and rough position.

1.8. RTK

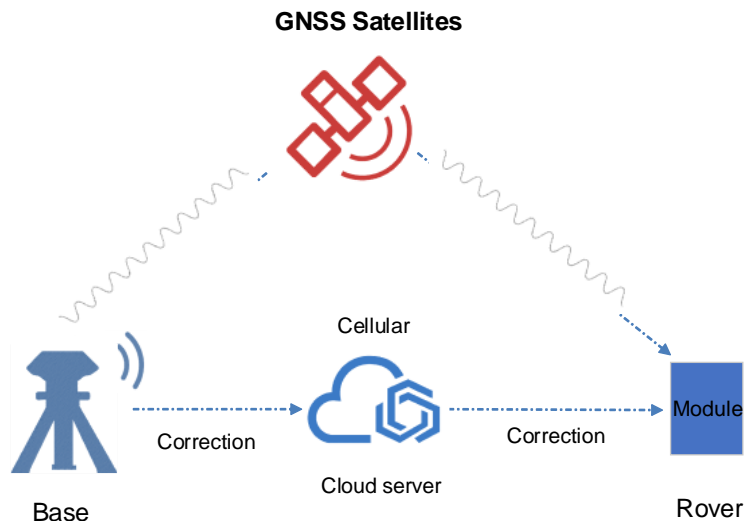

Figure 2: RTK Operation

1.8.1. RTK Rover

The module supports RTK functionality as rover.

Before implementing the RTK navigation technique, the module needs to receive the RTK correction messages via its UART interface. RTK differential correction data can be delivered either using a cellular module or other terrestrial network technologies. When set to the default configuration, the module will attempt to achieve the best positioning accuracy based on the received correction data. Once the RTK differential data is validated to be used by the position engine, the module will enter RTK float mode. Once the module's internal position engine decodes the carrier phase ambiguities, it will achieve the RTK fixed mode. The expected accuracy at RTK fixed mode is lower than 20 cm.

The convergence time refers to the interval as the module internal position engine switching from RTK float mode to RTK fixed mode. It typically takes less than 60 s to fix the carrier phase ambiguities.

1.8.2. RTK Base Station

The module supports RTCM data output as a base station.

The module supports Base station Survey-in mode, and the receiver mode can be set as "ECEF mode" through corresponding command. For more information about the command, see [document \[1\] protocol specification](#) and [document \[2\] base station mode application note](#). The module can be set to use a previously surveyed coordinate set of the base station antenna position. Provided that the surveyed position has been professionally captured during a geodic survey, this method can be the best option in terms of accuracy.

The module can also set as "Search-mode" by the corresponding command, which means the module can self-survey its position (coordinates) without using measured position data. When this search mode is adopted, the user provides the convergence time and 3D position threshold. The receiver will self-survey its position during this period and accumulate the data less than the 3D position threshold, and then calculate its average position. Once the convergence time has elapsed, the module will start running in static mode and output the configured RTCM reference station messages.

1.9. Firmware Upgrade

The module is delivered with preprogrammed firmware. Quectel may release firmware versions that contain bug fixes or performance optimizations. It's highly important to implement a firmware upgrade mechanism in your system. A firmware upgrade is the process of transferring a binary file image to the receiver and storing it in the non-volatile flash. For more information, see [document \[3\] firmware upgrade guide](#).

2 Pin Assignment

The module is equipped with 79 LGA pins by which the module can be mounted on your PCB.

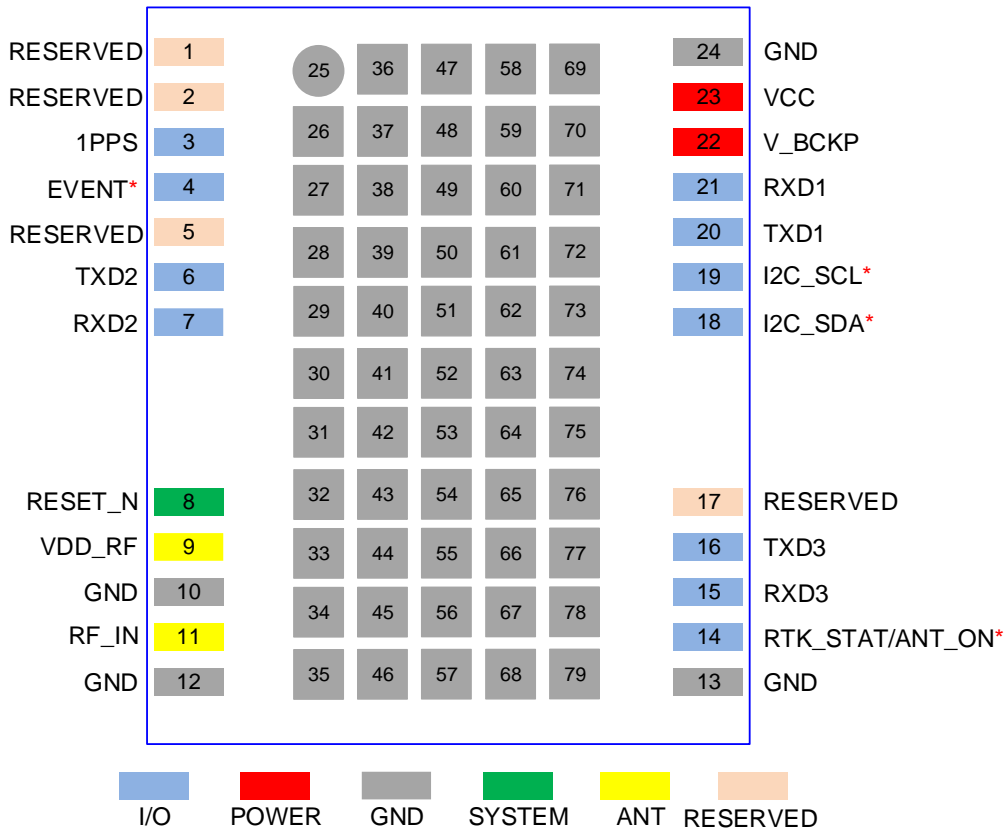

Figure 3: Pin Assignment

Table 5: Parameter Definition

Parameter	Description
AI	Analog Input
DI	Digital Input
DO	Digital Output
DIO	Digital Input/Output

Parameter	Description
PI	Power Input
PO	Power Output

Table 6: Pin Description

Function	Name	No.	I/O	Description	DC Characteristics	Remarks
Power	VCC	23	PI	Main power supply	$V_{Imin} = 3.0\text{ V}$ $V_{Inom} = 3.3\text{ V}$ $V_{Imax} = 3.6\text{ V}$	Requires clean and steady voltage.
	V_BCKP	22	PI	Backup power supply for backup domain	$V_{Imin} = 2.0\text{ V}$ $V_{Inom} = 3.3\text{ V}$ $V_{Imax} = 3.6\text{ V}$	V_BCKP must be connected to power supply for startup, and it should always be powered if hot (warm) start is needed.
I/O	TXD1	20	DO	UART1 Transmits data	$V_{OLmax} = 0.4\text{ V}$ $V_{OHmin} = VCC - 0.4\text{ V}$	UART1 interface supports standard NMEA message, PQTM message, RTCM message, debugging data and firmware upgrade.
	RXD1	21	DI	UART1 Receives data	$V_{ILmin} = 0\text{ V}$ $V_{ILmax} = 0.2\text{ V} \times VCC$ $V_{IHmin} = 0.7\text{ V} \times VCC$ $V_{IHmax} = 1.1\text{ V} \times VCC$	
	TXD2	6	DO	UART2 Transmits data	$V_{OLmax} = 0.4\text{ V}$ $V_{OHmin} = VCC - 0.4\text{ V}$	UART2 interface supports standard NMEA message, PQTM message, RTCM message and firmware upgrade.
	RXD2	7	DI	UART2 Receives data	$V_{ILmin} = 0\text{ V}$ $V_{ILmax} = 0.2\text{ V} \times VCC$ $V_{IHmin} = 0.7\text{ V} \times VCC$ $V_{IHmax} = 1.1\text{ V} \times VCC$	
	TXD3	16	DO	UART3 Transmits data	$V_{OLmax} = 0.4\text{ V}$ $V_{OHmin} = VCC - 0.4\text{ V}$	UART3 interface supports standard NMEA message, PQTM message, RTCM message and firmware upgrade.
	RXD3	15	DI	UART3 Receives data	$V_{ILmin} = 0\text{ V}$ $V_{ILmax} = 0.2\text{ V} \times VCC$ $V_{IHmin} = 0.7\text{ V} \times VCC$ $V_{IHmax} = 1.1\text{ V} \times VCC$	
	I2C_SDA*	18	DIO	I2C serial data	$V_{ILmin} = 0\text{ V}$ $V_{ILmax} = 0.2\text{ V} \times VCC$ $V_{IHmin} = 0.7\text{ V} \times VCC$ $V_{IHmax} = 1.1\text{ V} \times VCC$	I2C interface supports standard NMEA message, PQTM message and RTCM message.
	I2C_SCL*	19	DI	I2C serial clock	$V_{OLmax} = 0.4\text{ V}$ $V_{OHmin} = VCC - 0.4\text{ V}$	

Function	Name	No.	I/O	Description	DC Characteristics	Remarks
	RTK_STAT/ ANT_ON*	14	DO	Indicates RTK status/ Power control for external LNA or active antenna	$V_{OLmax} = 0.4\text{ V}$ $V_{OHmin} = VCC - 0.4\text{ V}$	<p>For RTK_STAT:</p> <ol style="list-style-type: none"> 1) If the pin outputs a high level, it indicates that the module enters the RTK fixed mode; 2) If the pin outputs a low level, it indicates that the module exits the RTK fixed mode; 3) If the pin outputs alternating pin level, it indicates that the module receives the correct RTCM data and does not enter the RTK fixed mode. <p>RTK_STAT/ANT_ON pin is no voltage output in Backup mode.</p>
	1PPS	3	DO	One pulse per second	$V_{OLmax} = 0.4\text{ V}$ $V_{OHmin} = VCC - 0.4\text{ V}$	<p>Synchronized on rising edge.</p> <p>If unused, leave the pin N/C.</p>
	EVENT*	4	DI	Event triggering	$V_{ILmin} = 0\text{ V}$ $V_{ILmax} = 0.2\text{ V} \times VCC$ $V_{IHmin} = 0.7\text{ V} \times VCC$ $V_{IHmax} = 1.1\text{ V} \times VCC$	Provide event inputs with adjustable input frequentness and polarity.
	RF_IN	11	AI	GNSS antenna interface	-	50 Ω characteristic impedance.
ANT	VDD_RF	9	PO	Supplies power for external RF components	$V_{Onom} = VCC$	<p>$VDD_RF = VCC$, the output current capacity depends on VCC.</p> <p>Typically used to supply power for an external active antenna or LNA.</p> <p>If unused, leave the pin N/C.</p>
System	RESET_N	8	DI	Resets the module	$V_{ILmin} = 0\text{ V}$ $V_{ILmax} = 0.66\text{ V}$	Active low.

Function	Name	No.	I/O	Description	DC Characteristics	Remarks
GND	GND	10, 12, 13, 24–79	-	Ground	-	Ensure a good GND connection to all module GND pins, preferably with a large ground plane.
RESERVED	RESERVED	1, 2, 5, 17	-	Reserved	-	These pins must be left N/C and cannot be connected to power or GND.

NOTE

Leave RESERVED and unused pins N/C.

3 Power Management

The module features an optimized power architecture with built-in autonomous energy saving capabilities to minimize power consumption at any given time. The receiver can be used in two operating modes: Backup mode for optimum power consumption and Continuous mode for optimum performance.

3.1. Power Unit

VCC is the supply voltage pin of the module. It supplies the PMU which in turn supplies the entire system. The load current of the VCC pin varies according to VCC voltage level, processor load and satellite acquisition. It is important to supply sufficient current and make sure the power supply is clean and stable.

The V_BCKP pin supplies the backup domain, which includes RTC. To achieve quick startup and improve TTFF, the backup domain power supply should be valid at the times during Backup mode.

VDD_RF is an output pin, equal in voltage to the VCC input. In the Continuous mode, VDD_RF supplies the external active antenna or the LNA. Only if the VCC is turned off, VDD_RF is turned off.

The module's internal power supply is shown below:

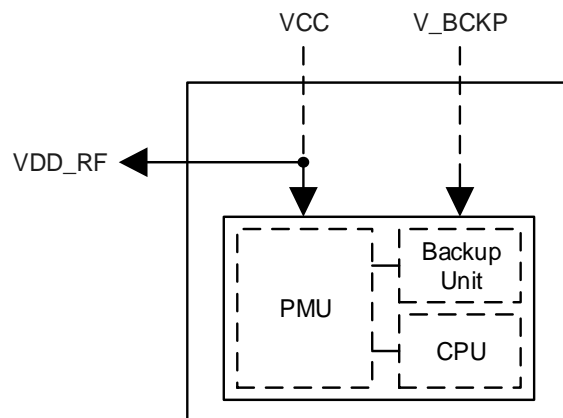

Figure 4: Internal Power Supply

3.2. Power Supply

3.2.1. VCC

The VCC is the supply voltage pin that supplies BB and RF.

Module power consumption may vary by several orders of magnitude, especially when power saving mode is enabled. Therefore, it is important for the power supply to be able to sustain peak power for a short time, ensuring that the load current does not exceed the rated value. When the module starts up or switches from the Backup mode to the Continuous mode, VCC must charge the internal capacitors in the core domain. In some cases, this can lead to a significant current drain.

For low-power applications using power saving mode, it is important for the LDO at the power supply or module input to be able to provide sufficient current when the module is switched from Backup mode to Continuous mode. An LDO with a high PSRR should be chosen for good performance. In addition, a TVS, and a combination of a 10 μ F, a 100 nF and a 33 pF decoupling capacitor network should be added near the VCC pin. The minimum value capacitor should be the closest to the VCC pin.

It is recommended to use a fast-discharging LDO voltage regulator, which can ensure a quick voltage drop when the VCC power is cut off. It is not recommended to use a switching DC-DC converter.

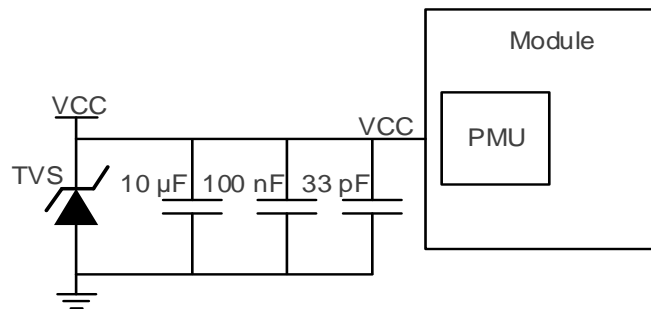

Figure 5: VCC Input Reference Circuit

NOTE

Ensure the module VCC is controlled by MCU to save power or restart the module should it enters an abnormal state.

3.2.2. V_BCKP

The V_BCKP pin supplies power for the backup domain. Use of valid time and GNSS orbit data at startup allows GNSS hot (warm) start. V_BCKP must be connected to power supply for startup, and it should always be powered if hot (warm) start is needed.

If there is a constant power supply in your system, it can be used to provide a suitable voltage to power V_BCKP.

It is recommended to place a TVS and a combination of a 4.7 μF , a 100 nF and a 33 pF decoupling capacitor near the V_BCKP pin. The figure below illustrates the reference design for powering the backup domain.

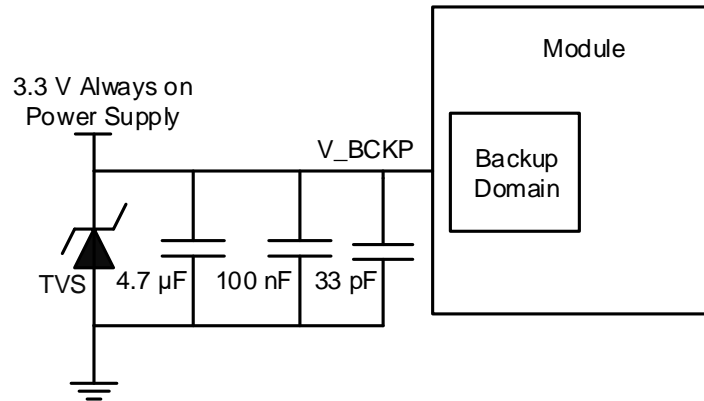

Figure 6: Backup Domain Input Reference Circuit

V_BCKP can also be powered by a 3.7 V lithium battery. It is recommended to use MCU to control the enable pin of LDO via MCU, as shown below.

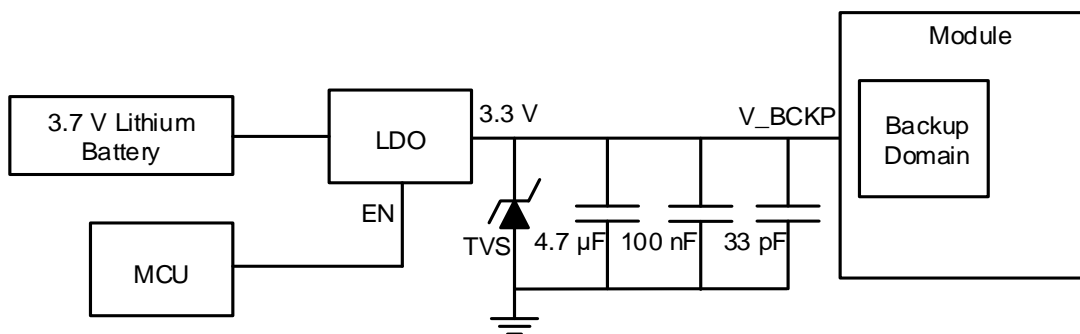

Figure 7: Reference Power Supply Circuit with 3.7 V Lithium Battery

NOTE

1. If V_BCKP is below the minimum value of the recommended operating voltage, the module cannot work normally.
2. It is recommended to control the module V_BCKP via MCU to restart the module if the module enters an abnormal state.

3.3. Power Modes

3.3.1. Feature Comparison

The module features supported in different modes are listed in the table below.

Table 7: Feature Comparison in Different Power Modes

Features	Continuous	Backup
NMEA/RTCM from UART	●	-
1PPS	●	-
RF	●	-
Acquisition & Tracking	●	-
Power Consumption	High	Low
Positioning Accuracy	High	-

3.3.2. Continuous Mode

If VCC and V_BCKP are powered on, the module automatically enters the Continuous mode that comprises acquisition mode and tracking mode. In acquisition mode, the module starts to search for satellites and to determine visible satellites, coarse frequency, as well as the code phase of satellite signals. Once the acquisition is completed, the module automatically switches to tracking mode. In tracking mode, the module tracks satellites and demodulates the navigation data from specific satellites.

3.3.3. Backup Mode

For power-sensitive applications, the module supports a Backup mode to reduce power consumption. Only backup domain is active in the Backup mode and it keeps track of time.

- Enter Backup mode: Cut off the power supply of VCC for at least 1 s and keep V_BCKP powered.
- Exit Backup mode: Restore the VCC power supply.

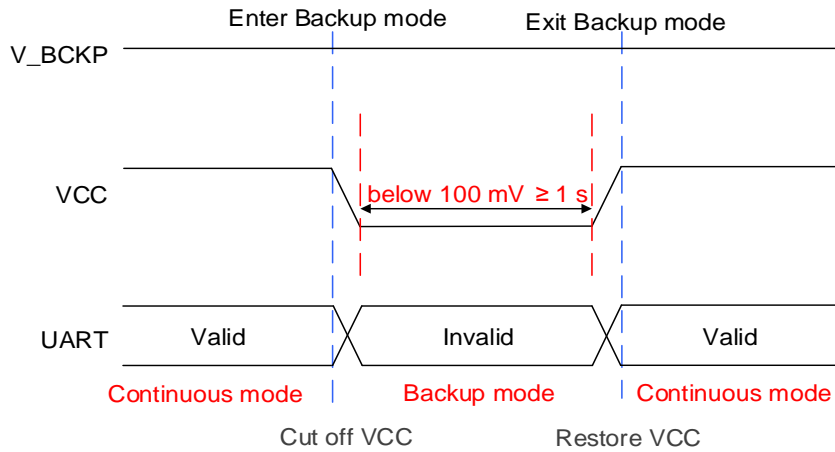

Figure 8: Enter/Exit Backup Mode Sequence

NOTE

Ensure a stable V_BCKP voltage without rush or drop when the VCC is switched on or off.

3.4. Power-up Sequence

Once the VCC and V_BCKP are powered up, the module starts up automatically and the voltage should rise rapidly in less than 50 ms.

To ensure the correct power-up sequence, the backup unit should start up no later than the PMU. Hence, the V_BCKP must be powered simultaneously with the VCC or before it.

Ensure that the VCC and V_BCKP have no rush or drop during rising time, and then keep the voltage stable. The recommended ripple is < 50 mV.

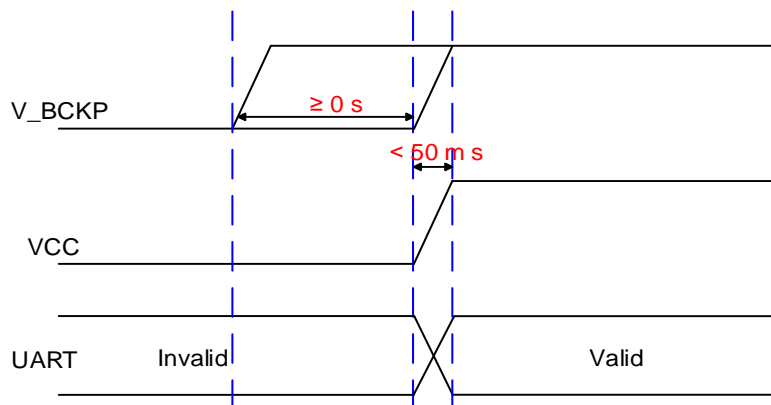

Figure 9: Power-up Sequence

3.5. Power-down Sequence

Once the VCC and V_BCKP are shut down, the module turns off automatically and the voltage should drop quickly within less than 50 ms. It is recommended to use a voltage regulator that supports fast discharging.

To avoid abnormal voltage conditions, if VCC and V_BCKP fall below the minimum specified value, the system must initiate a power-on restart by lowering VCC and V_BCKP to less than 100 mV for at least 1 s.

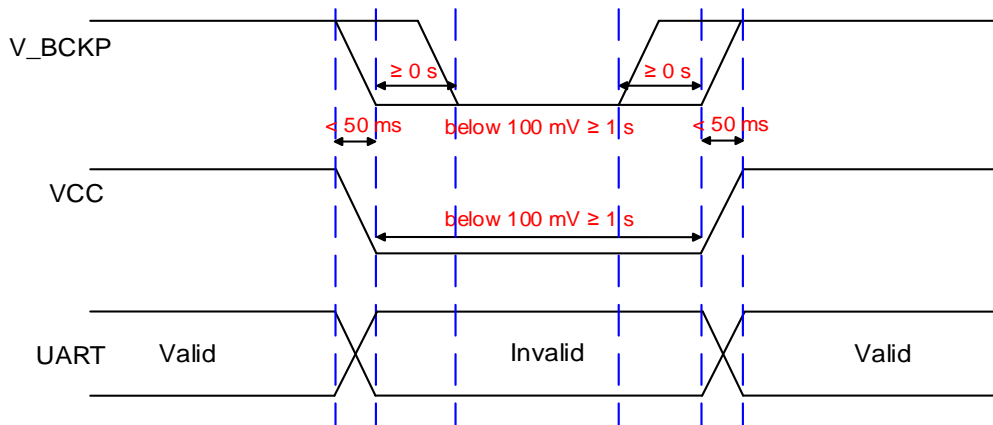

Figure 10: Power-down and Power-on Restart Sequence

4 Application Interfaces

4.1. I/O Pins

4.1.1. Communication Interfaces

The following interfaces can be used for data reception and transmission.

4.1.1.1. UART1 Interface

The module has one UART1 interface with the following features:

- Supports standard NMEA message, PQTM message, RTCM message, debugging data and firmware upgrade.
- Supported baud rates: 9600 bps, 115200 bps, 230400 bps, 460800 bps and 921600 bps.
- Hardware flow control and synchronous operation are not supported.

For more information, see [document \[1\] protocol specification](#).

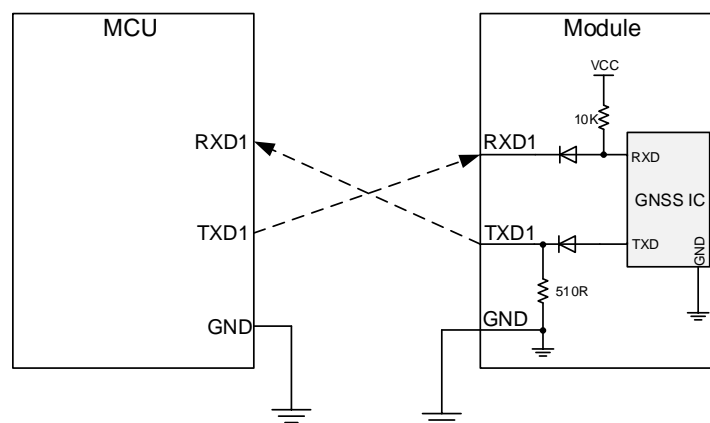

Figure 11: UART1 Interface Reference Design

A reference design is shown in the figure above. For more information, see [document \[4\] reference design](#).

NOTE

1. UART1 interface default settings may vary depending on software version. See the relevant software versions for details.
2. If the I/O voltage of MCU is not matched with the module, a level-shifting circuit must be selected. Recommended level-shifting chip: SN74AVC4T245. Level-shifting chips with series resistors such as TXB series are not recommended.

4.1.1.2. UART2 Interface

The module has one UART2 interface with the following features:

- Supports standard NMEA message, PQTM message, RTCM message and firmware upgrade.
- Supported baud rates: 9600 bps, 115200 bps, 230400 bps, 460800 bps and 921600 bps.
- Hardware flow control and synchronous operation are not supported.

For more information, see [document \[1\] protocol specification](#).

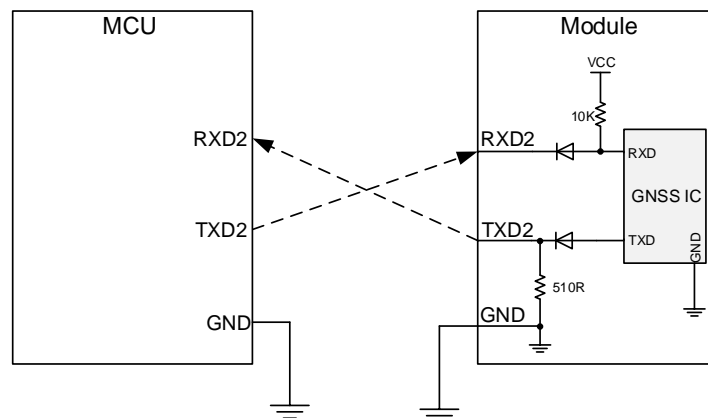

Figure 12: UART2 Interface Reference Design

A reference design is shown in the figure above. For more information, see [document \[4\] reference design](#).

NOTE

1. UART2 interface default settings may vary depending on software version. See the relevant software versions for details.
2. If the I/O voltage of MCU is not matched with the module, a level-shifting circuit must be selected. Recommended level-shifting chip: SN74AVC4T245. Level-shifting chips with series resistors such as TXB series are not recommended.

4.1.1.3. UART3 Interface

The module has one UART3 interface with the following features:

- Supports standard NMEA message, PQTM message, RTCM message and firmware upgrade.
- Supported baud rates: 9600 bps, 115200 bps, 230400 bps, 460800 bps and 921600 bps.
- Hardware flow control and synchronous operation are not supported.

For more information, see [document \[1\] protocol specification](#).

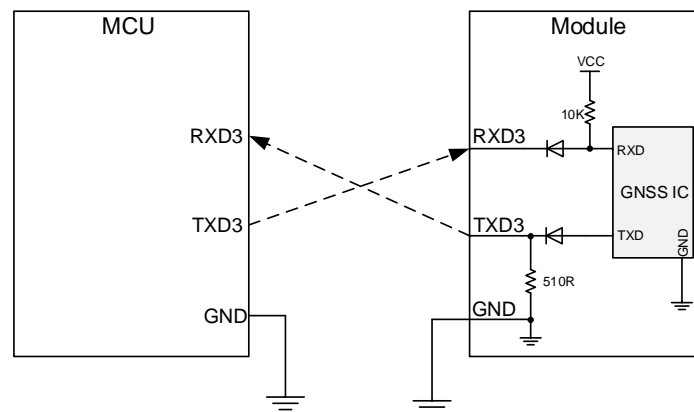

Figure 13: UART3 Interface Reference Design

A reference design is shown in the figure above. For more information, see [document \[4\] reference design](#).

NOTE

1. UART3 interface default settings may vary depending on software version. See the relevant software versions for details.
2. If the I/O voltage of MCU is not matched with the module, a level-shifting circuit must be selected. Recommended level-shifting chip: SN74AVC4T245. Level-shifting chips with series resistors such as TXB series are not recommended.

4.1.1.4. I2C Interface*

The module provides one I2C interface with the following features:

- I2C interface supports standard NMEA message, PQTM message and RTCM message.
- Supports fast mode, with bit rates up to 400 kbps.
- Operates as a slave.
- Built-in 2.2 kΩ pull-up resistor.

For more information, see [document \[1\] protocol specification](#).

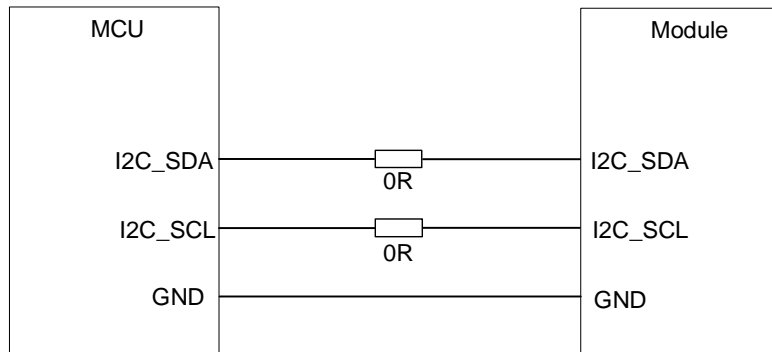

Figure 14: I2C Interface Reference Design

A reference design is shown in the figure above. For more information, see [document \[4\] reference design](#).

NOTE

If the I/O voltage of MCU is not matched with that of the module, a level-shifting circuit must be selected. Recommended level-shifting chip: SN74AVC4T245. Level-shifting chips with series resistors such as TXB series are not recommended.

4.1.2. RTK_STAT/ANT_ON*

The RTK_STAT is an indicator pin for RTK positioning status and the default frequency is 10 Hz. This pin is set to a high level at startup. If the pin outputs a high level, it indicates that the module enters the RTK fixed mode. If the pin outputs a low level, it indicates that the module exits the RTK fixed mode. If the pin outputs alternating pin level, it indicates that the module receives the correct RTCM data and does not enter the RTK fixed mode. The RTK_STAT is no voltage output in Backup mode.

ANT_ON is used to control the external LNA or active antenna power supply. It outputs a high level in Continuous mode and is no voltage output in Backup mode.

4.1.3. 1PPS

The 1PPS output pin can be used for time pulse signals, it generates a one pulse per second periodic signal synchronized to a GNSS time grid with intervals. Maintaining high accuracy of 1PPS requires visible satellites in an open sky environment and powered VCC. See [Table 3: Product Performance](#) for details about pulse accuracy.

4.2. System Pins

4.2.1. RESET_N

RESET_N is an input pin. The module can be reset by driving the RESET_N low for at least 100 ms and then releasing it.

By default, the RESET_N pin is pulled up internally to VCC with a 20 kΩ resistor, thus no external pull-up circuit is allowed for this pin.

An OC driver circuit as shown below is recommended to control the RESET_N pin.

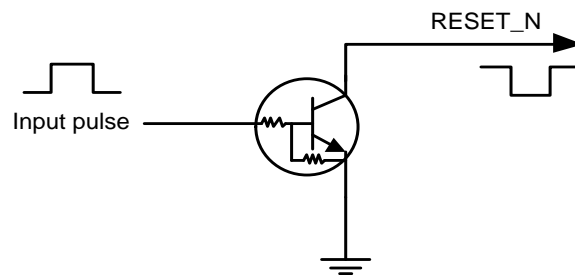

Figure 15: Reference OC Circuit for Module Reset

The following figure shows the reset sequence of the module.

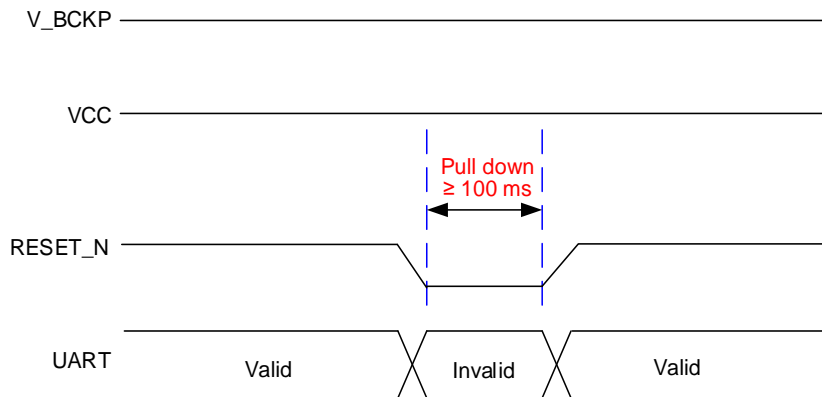

Figure 16: Reset Sequence

NOTE

RESET_N must be connected so that it can be used to reset the module if it enters an abnormal state.

5 Design

This chapter explains the reference design of RF section and recommended footprint of the module. GNSS receiver could be vulnerable to environmental interference. To learn the details about interference and ensuring interference immunity, see [document \[5\] GNSS antenna application note](#).

5.1. Antenna Specification

The module can be connected to a dedicated active quad-band GNSS antenna to receive GNSS satellite signals. The recommended antenna specifications are given in the table below.

Table 8: Recommended Antenna Specifications

Antenna Type	Specifications
Active Antenna	Frequency Range: 1559–1606 MHz & 1196–1284 MHz & 1164–1189 MHz Polarization: RHCP VSWR: < 2 (Typ.) Passive Antenna Gain: > 3 dBi Active Antenna Noise Figure: < 2.5 dB Active Antenna Total Gain: 25–43 dB ⁵ Phase Center Offset: < 20 mm ⁶ Phase Center Variation: < 20 mm ⁶ Axial Ratio:< 3 dB ⁶ -3 dB Beamwidth: > 90° ⁶ Out-of-band Rejection: > 30 dB

NOTE

For recommended antenna selection and design, see [document \[5\] GNSS antenna application note](#) or contact Quectel Technical Support (support@quectel.com).

⁵ The total antenna gain equals the internal LNA gain minus the total insertion loss of cables and components inside the antenna.

⁶ When RTK function is used to achieve high precision positioning, the antenna should meet the specifications recommended above.

5.2. Active Antenna Reference Design

A typical reference design of an active antenna is illustrated in the following figure. To further mitigate the impact of out-of-band signals on GNSS module performance, you must choose the active antenna whose SAW filter is placed in front of the LNA in the internal framework. **DO NOT** place the LNA in the front.

If the active antenna is supplied by VDD_RF pin, it is important to consider the operating voltage range of the antenna and the voltage drop on the power supply circuit. The voltage drop is caused by the inductance on the VDD_RF internal circuit, the resistor (R2) and the inductor (L1) in the external power supply circuit. The minimum operating voltage of the selected active antenna must meet the circuit design characteristics.

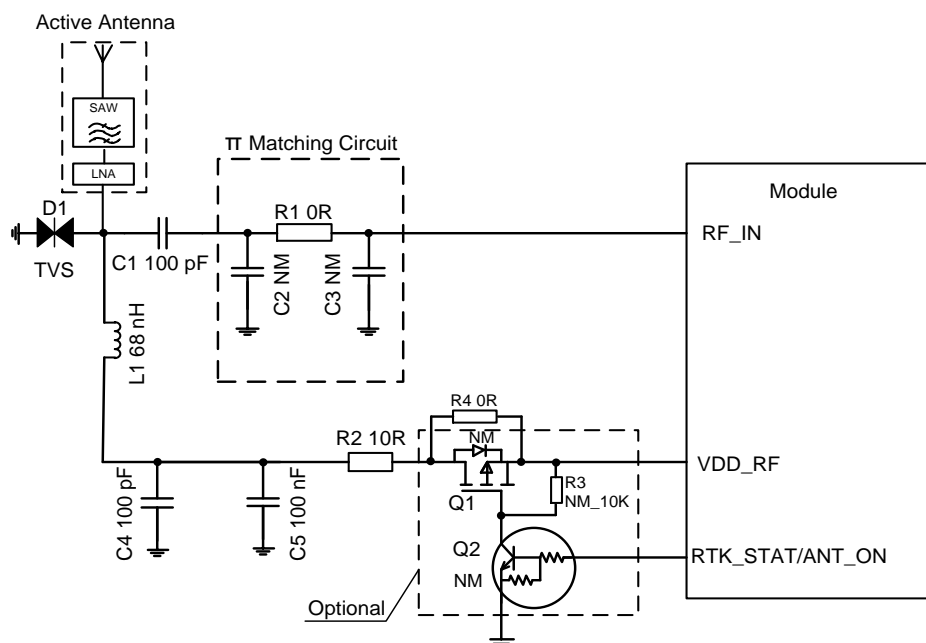

Figure 17: Active Antenna Reference Design

C1 is used for DC blocking from VDD_RF. C2, R1 and C3 components are reserved for matching antenna impedance. By default, R1 is 0 Ω, while C2 and C3 are not mounted; C1 is 100 pF; D1 is an electrostatic discharge (ESD) protection device to protect the RF signal input from the potential damage caused by ESD. The junction capacitance of D1 cannot be more than 0.6 pF and a transient voltage suppressor is recommended.

The inductor L1 is used to prevent the RF signal from leaking into the VDD_RF and to prevent noise propagation from the VDD_RF to the antenna. The L1 inductor routes the bias voltage to the active antenna without losses. Place L1, C4 and C5 close to the antenna interface and route the proximal end of L1 pad on the RF trace. The recommended value of L1 should be at least 68 nH. The R2 resistor is used to protect the module in case the active antenna is short-circuited to the ground plane. RF trace impedance should be controlled to 50 Ω and trace length should be kept as short as possible. For more

information about RF layout, see [document \[6\] RF Layout application note](#).

The active antenna is always powered when R4 is mounted. When it is not mounted, while Q1, Q2 and R3 are mounted, the active antenna power supply can be controlled through ANT_ON pin. When the ANT_ON pin outputs high level, the antenna is powered; otherwise, the antenna is not powered.

NOTE
The passive antenna is not recommended.

5.3. Recommended Footprint

The figure below illustrates a module footprint. These are recommendations, not specifications.

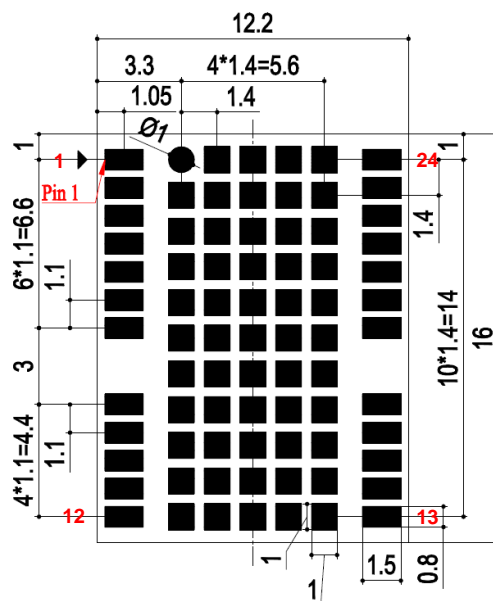

Unlabeled tolerance: +/-0.2mm

Figure 18: Recommended Footprint

NOTE
Keep at least 3 mm between the module and other components on the motherboard to improve soldering quality and maintenance convenience.

6 Electrical Specification

6.1. Absolute Maximum Ratings

Absolute maximum ratings for power supply and voltage on digital pins of the Quectel LG290P (03) module are listed in the table below.

Table 9: Absolute Maximum Ratings

Parameter	Description	Min.	Max.	Unit
VCC	Main Power Supply Voltage	-0.3	3.6	V
V_BCKP	Backup Power Supply Voltage	-0.3	3.6	V
V _{IN_IO}	Input Voltage at I/O Pins	-0.2	VCC + 0.3	V
P _{RF_IN}	Input Power at RF_IN	-	10	dBm
T _{storage}	Storage Temperature	-40	90	°C

NOTE

Stressing the device beyond the “Absolute Maximum Ratings” may cause permanent damage. The product is not protected against over-voltage or reversed voltage. Therefore, it is necessary to use appropriate protection diodes to keep voltage spikes within the parameters given in the table above.

6.2. Recommended Operating Conditions

All specifications are at an ambient temperature of +25 °C. Extreme operating temperatures can significantly impact the specified values. Applications operating near the temperature limits should be tested to ensure specification validity.

Table 10: Recommended Operating Conditions

Parameter	Description	Min.	Typ.	Max.	Unit
VCC	Main Power Supply Voltage	3.0	3.3	3.6	V
V_BCKP	Backup Power Supply Voltage	2.0	3.3	3.6	V
IO_Domain	Digital I/O Pin Domain Voltage	-	VCC	-	V
V _{IL}	Digital I/O Pin Low-level Input Voltage	0	-	0.2 × VCC	V
V _{IH}	Digital I/O Pin High-level Input Voltage	0.7 × VCC	-	1.1 × VCC	V
V _{OL}	Digital I/O Pin Low-level Output Voltage	-	-	0.4	V
V _{OH}	Digital I/O Pin High-level Output Voltage	VCC - 0.4	-	-	V
RESET_N	Low-level Input Voltage	0	-	0.66	V
VDD_RF	VDD_RF Output Voltage	-	VCC	-	V
I _{VDD_RF}	VDD_RF Output Current	-	-	100	mA
T_operating	Operating Temperature	-40	25	+85	°C

NOTE

1. Operation beyond the “Operating Conditions” is not recommended and extended exposure beyond the “Operating Conditions” may affect device reliability.
2. Digital I/O Pin mentioned in the table above refers to all digital pins specified in [Table 6: Pin Description](#) except for RESET_N.

6.3. Supply Current Requirement

The following table lists the supply current values of the total system that may be applied. Actual power requirements may vary depending on processor load, external circuits, firmware version, the number of tracked satellites, signal strength, startup type and test duration.

Table 11: Supply Current

Parameter	Description	Condition	$I_{Typ.}^7$	I_{PEAK}^7
I_{VCC}^8	Current at VCC	Acquisition	99 mA	135 mA
		Tracking	99 mA	135 mA
$I_{V_BCKP}^9$	Current at V_BCKP	Continuous mode	3 μ A	40 μ A
		Backup mode	12 μ A	57 μ A

NOTE

The above power consumption values are measured within the respective modes, excluding transient pulse currents that occur during power-up and mode transition.

6.4. ESD Protection

Static electricity occurs naturally and it may damage the module. Therefore, applying proper ESD countermeasures and handling methods is imperative. For example, wear anti-static gloves during the development, production, assembly, and testing of the module; add ESD protection components to the ESD sensitive interfaces and points in the product design.

Measures to ensure protection against ESD damage when handling the module:

- When mounting the module onto a motherboard, make sure to connect the GND first, and then the RF_IN pin.
- When handling the RF_IN pin, do not come into contact with any charged capacitors or materials that may easily generate or store charges (such as patch antenna, coaxial cable and soldering iron).
- When soldering the RF_IN pin, make sure to use an ESD safe soldering iron (tip).

⁷ Tested at room temperature, with typical operating voltage, and satellites signal of -130 dBm configured by the instrument.

⁸ Used to determine maximum current capability of power supply.

⁹ Used to determine required battery current capability.

7 Mechanical Dimensions

This chapter describes the mechanical dimensions of the module. All dimensions are in millimeters (mm). The dimensional tolerances are ± 0.20 mm, unless otherwise specified.

7.1. Top, Side and Bottom View Dimensions

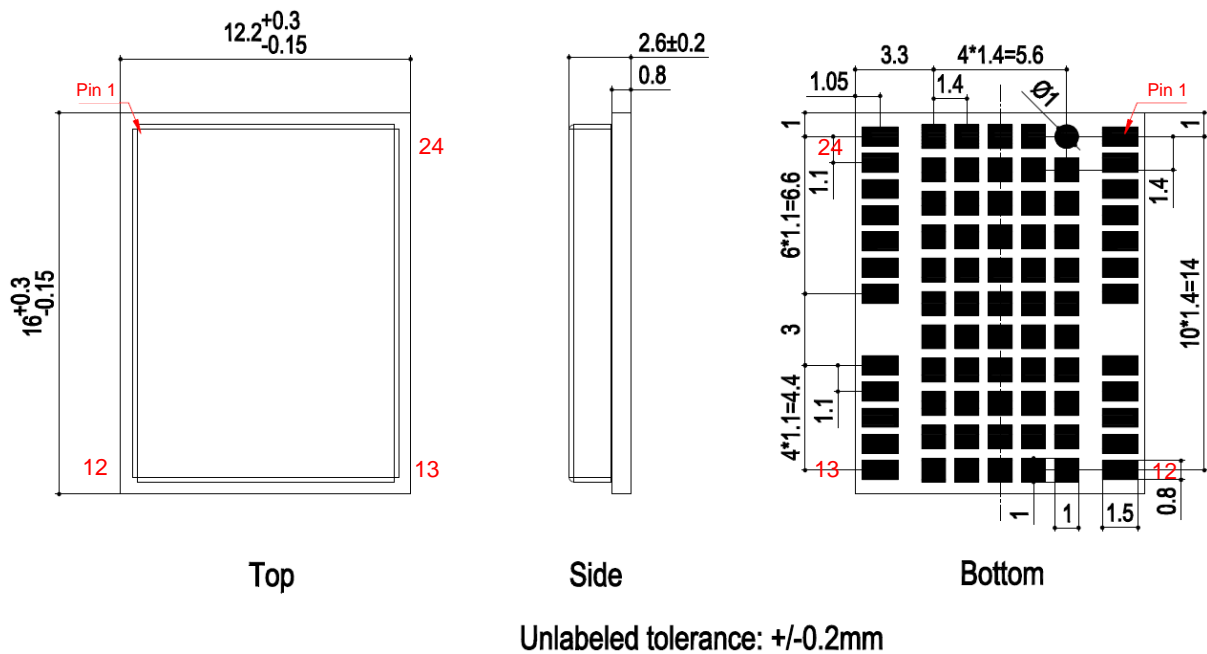

Figure 19: Top, Side and Bottom View Dimensions

NOTE

The module's coplanarity standard: ≤ 0.13 mm.

7.2. Top and Bottom Views

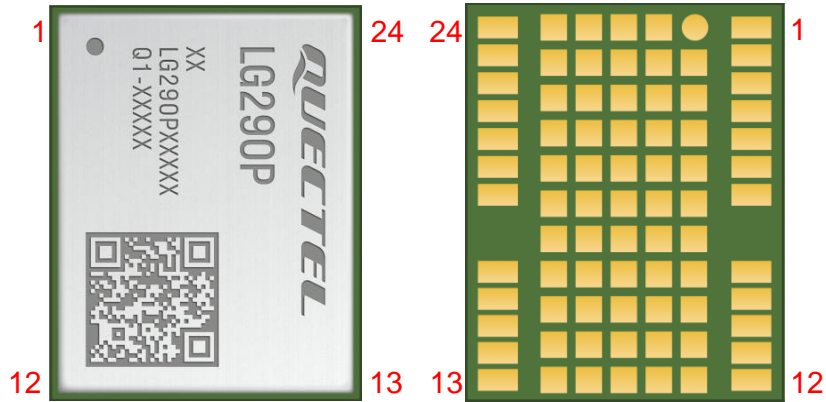

Figure 20: Top and Bottom Module Views

NOTE

The images above are for illustration purposes only and may differ from the actual module. For authentic appearance and label, see the module received from Quectel.

8 Product Handling

8.1. Packaging Specification

This chapter outlines the key packaging parameters and processes. All figures below are for reference purposes only, as the actual appearance and structure of packaging materials may vary in delivery.

The modules are packed in a tape and reel packaging as specified in the sub-chapters below.

8.1.1. Carrier Tape

Carrier tape dimensions are illustrated in the following figure and table:

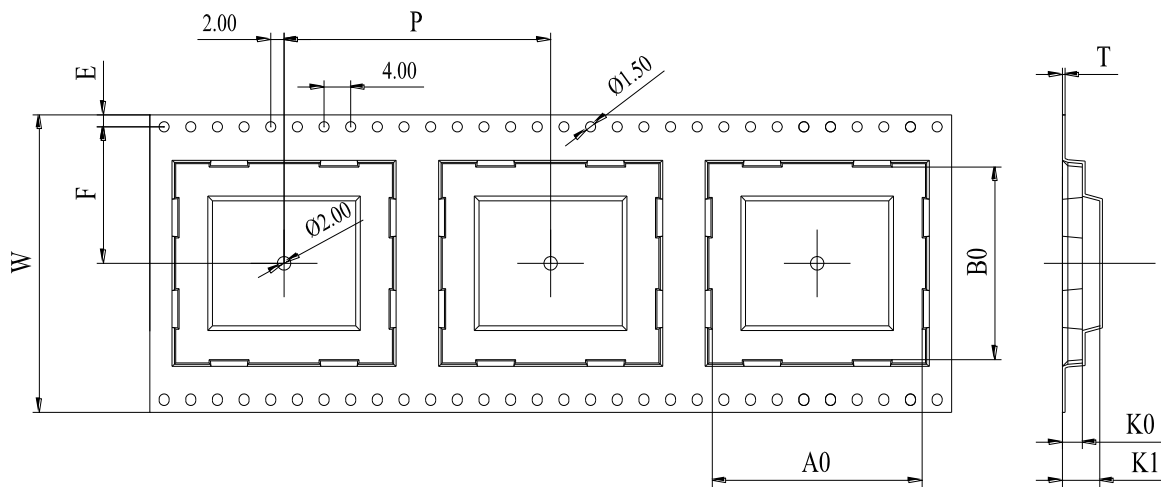

Figure 21: Carrier Tape Dimension Drawing (Unit: mm)

Table 12: Carrier Tape Dimension Table (Unit: mm)

W	P	T	A0	B0	K0	K1	F	E
32	24	0.4	12.7	16.4	2.9	7.4	14.2	1.75

8.1.2. Plastic Reel

Plastic reel dimensions are illustrated in the following figure and table:

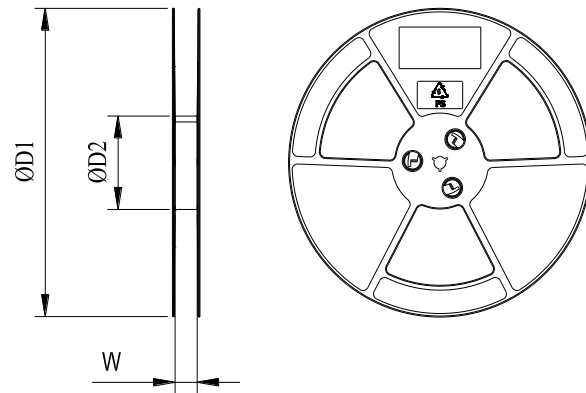

Figure 22: Plastic Reel Dimension Drawing

Table 13: Plastic Reel Dimension Table (Unit: mm)

ØD1	ØD2	W
330	100	32.5

8.1.3. Mounting Direction

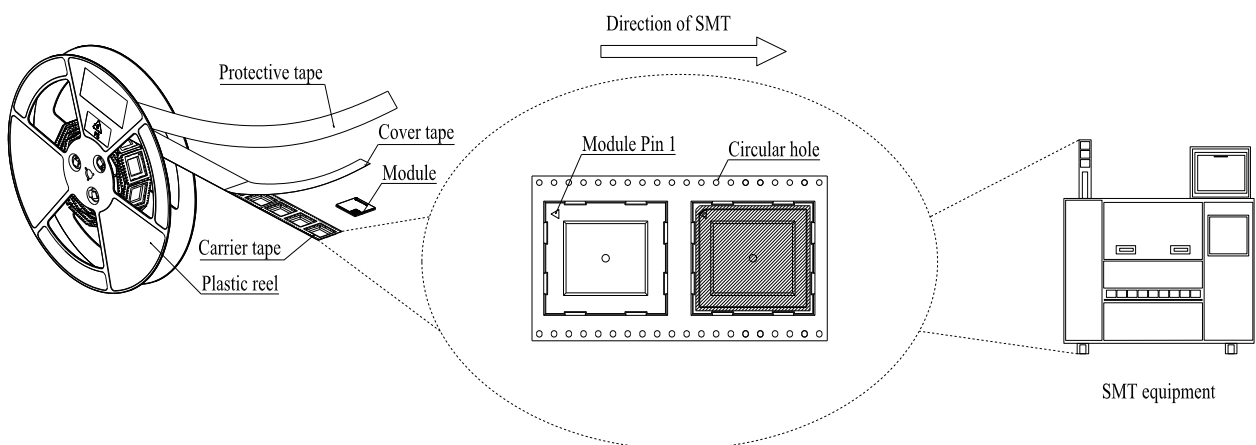
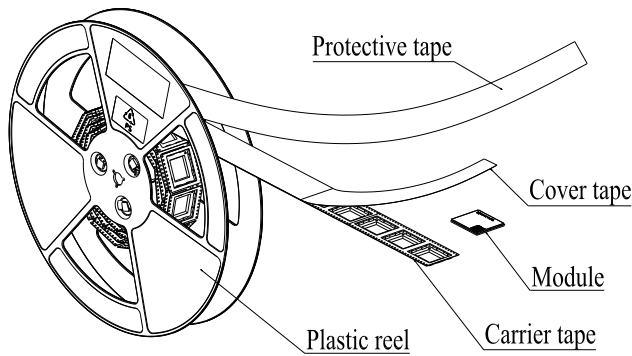

Figure 23: Mounting Direction

8.1.4. Packaging Process



Place the modules onto the carrier tape cavity and cover them securely with cover tape. Wind the heat-sealed carrier tape onto a plastic reel and apply a protective tape for additional protection. 1 plastic reel can pack 250 modules.

Place the packaged plastic reel, humidity indicator card and desiccant bag into a vacuum bag, and vacuumize it.

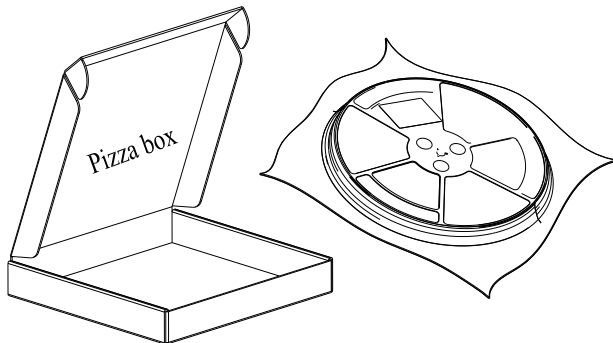
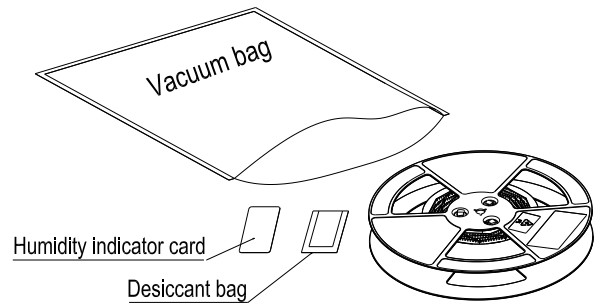

Place the vacuum-packed plastic reel into a pizza box.

Place the 4 packaged pizza boxes into 1 carton and seal it. 1 carton can pack 1000 modules.

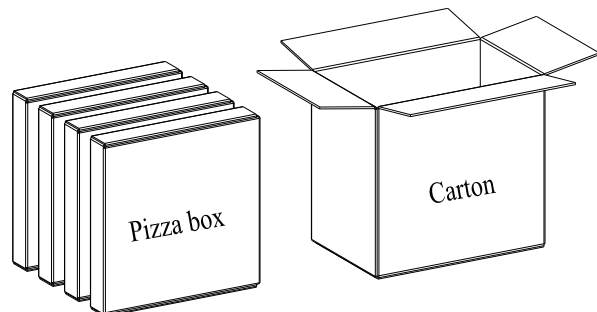

Pizza Box Size (mm): 365 × 345 × 56
 Carton Size (mm): 380 × 250 × 365

Figure 24: Packaging Process

8.2. Storage

The module is provided with vacuum-sealed packaging. MSL of the module is rated as 3. The storage requirements are shown below.

1. Recommended Storage Condition: the temperature should be 23 ± 5 °C and the relative humidity should be 35–60 %.
2. Shelf life (in a vacuum-sealed packaging): 12 months in Recommended Storage Condition.
3. Floor life: 168 hours ¹⁰ in a factory where the temperature is 23 ± 5 °C and relative humidity is below 60 %. After the vacuum-sealed packaging is removed, the module must be processed in reflow soldering or other high-temperature operations within 168 hours. Otherwise, the module should be stored in an environment where the relative humidity is less than 10 % (e.g., a dry cabinet).
4. The module should be pre-baked to avoid blistering, cracks and inner-layer separation in PCB under the following circumstances:
 - The module is not stored in Recommended Storage Condition;
 - Violation of the third requirement mentioned above;
 - Vacuum-sealed packaging is broken, or the packaging has been removed for over 24 hours;
 - Before module repairing.
5. If needed, the pre-baking should follow the requirements below:
 - The module should be baked for 24 hours at 120 ± 5 °C;
 - The module must be soldered to PCB within 24 hours after the baking, otherwise it should be put in a dry environment such as a dry cabinet.

NOTE

1. To avoid blistering, layer separation and other soldering issues, extended exposure of the module to the air is forbidden.
2. Take out the module from the package and put it on high-temperature-resistant fixtures before baking. If shorter baking time is desired, see *IPC/JEDEC J-STD-033* for the baking procedure.
3. Pay attention to ESD protection, such as wearing anti-static gloves, when touching the module.

¹⁰ This floor life is only applicable when the environment conforms to *IPC/JEDEC J-STD-033*. It is recommended to start the solder reflow process within 24 hours after the package is removed if the temperature and moisture do not conform to, or are not sure to conform to *IPC/JEDEC J-STD-033*. Do not unpack the modules in large quantities until they are ready for soldering.

8.3. Manufacturing and Soldering

Push the squeegee to apply solder paste on the stencil surface, thus making the paste fill the stencil openings and then penetrate the PCB. Apply proper force on the squeegee to produce a clean stencil surface on a single pass. For more information about the stencil thickness for the module, see [document \[7\] module stencil design requirements](#).

The recommended peak reflow temperature should be 235–246 °C, with 246 °C as the absolute maximum reflow temperature. To avoid module damage caused by repeated heating, it is recommended to mount the module only after reflow soldering the other side of the PCB. The recommended reflow soldering thermal profile (lead-free reflow soldering) and related parameters are shown in the figure and table below.

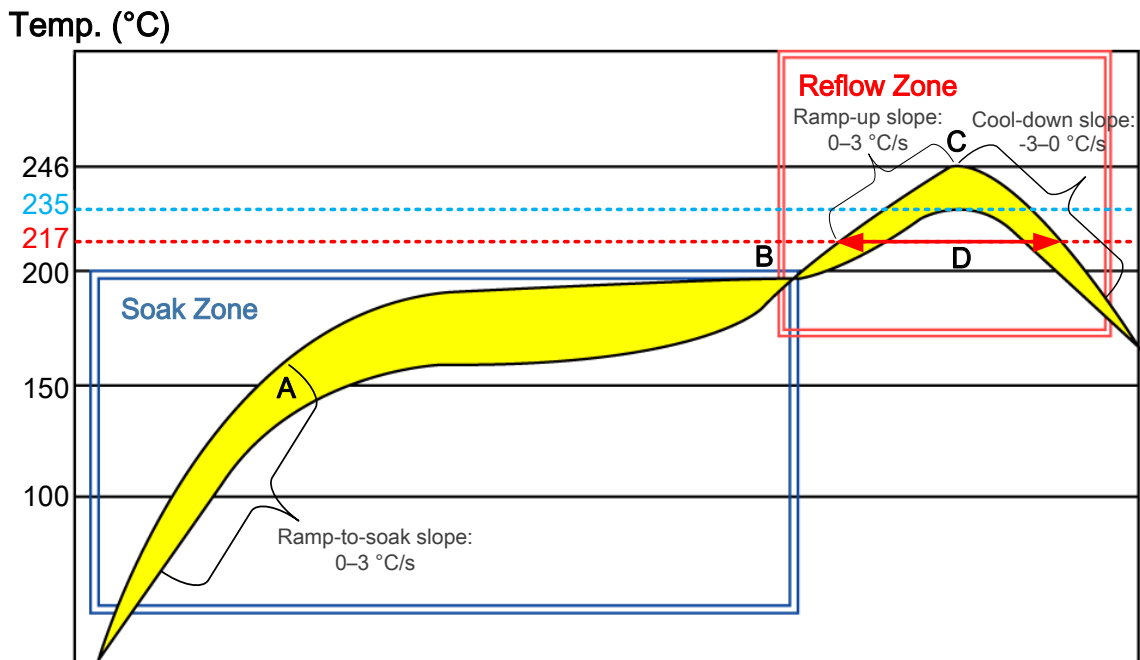

Figure 25: Recommended Reflow Soldering Thermal Profile

Table 14: Recommended Thermal Profile Parameters

Factor	Recommendation Value
Soak Zone	
Ramp-to-soak Slope	0–3 °C/s
Soak Time (between A and B: 150 °C and 200 °C)	70–120 s

Factor	Recommendation Value
Reflow Zone	
Ramp-up Slope	0–3 °C/s
Reflow Time (D: over 217 °C)	40–70 s
Max. Temperature	235–246 °C
Cool Down Slope	-3–0 °C/s
Reflow Cycle	
Max. Reflow Cycle	1

NOTE

1. The above profile parameter requirements are for the measured temperature of the solder joints. Both the hottest and coldest spots of solder joints on the PCB should meet the above requirements.
2. During manufacturing and soldering, or any other processes that may require direct contact with the module, **NEVER** wipe the module shielding can with organic solvents, such as acetone, ethyl alcohol, isopropyl alcohol, and trichloroethylene. Otherwise, the shielding can may become rusty.
3. The module shielding can is made of cupronickel base material. The Neutral Salt Spray Test has shown that after 12 hours the laser-engraved label information on the shielding can is still clearly identifiable and the QR code is still readable, although white rust may be found.
4. If a conformal coating is necessary for the module, **DO NOT** use any coating material that may chemically react with the PCB or shielding cover. Prevent the coating material from penetrating the module shield.
5. Avoid using ultrasonic technology for module cleaning since it can damage crystals inside the module.
6. Avoid using materials that contain mercury (Hg), as adhesives, for module processing, even if the materials are RoHS compliant and their mercury content is below 1000 ppm (0.1 %).
7. Corrosive gases may corrode the electronic components inside the module, affecting their reliability and performance, and potentially leading to a shortened service life that fails to meet the designed lifespan. Therefore, do not store or use unprotected modules in environments containing corrosive gases such as hydrogen sulfide, sulfur dioxide, chlorine, and ammonia.
8. Due to SMT process complexity, contact Quectel Technical Support in advance regarding any ambiguous situation, or any process (e.g., selective soldering, ultrasonic soldering) that is not addressed in [document \[8\] module SMT application note](#).

9 Labelling Information

The label of the Quectel GNSS modules contains important product information. The location of the product type number is shown in the figure below.

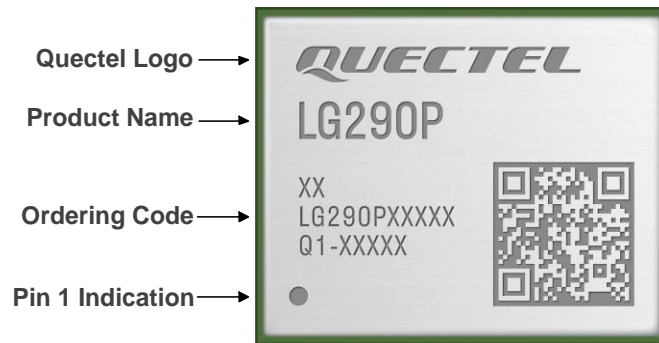

Figure 26: Labelling Information

The image above is for illustrative purposes only and may differ from the actual module. For authentic appearance and label, see the module received from Quectel.

10 Appendix References

Table 15: Related Documents

Document Name	
[1]	Quectel_LG290P(03)_GNSS_Protocol_Specification
[2]	Quectel_LG290P(03)_Base_Station_Mode_Application_Note
[3]	Quectel_LG290P(03)_Firmware_Upgrade_Guide
[4]	Quectel_LG290P(03)_Reference_Design
[5]	Quectel GNSS Antenna Application Note
[6]	Quectel RF Layout Application Note
[7]	Quectel Module Stencil Design Requirements
[8]	Quectel Module SMT Application Note

Table 16: Terms and Abbreviations

Abbreviation	Description
1PPS	One Pulse Per Second
AGNSS	Assisted GNSS (Global Navigation Satellite System)
BDS	BeiDou Satellite Navigation System
BDSABS	BeiDou Satellite-based Augmentation System
bps	bit(s) per second
CEP	Circular Error Probable
DR	Dead Reckoning
EGNOS	European Geostationary Navigation Overlay Service

Abbreviation	Description
ESD	Electrostatic Discharge
GAGAN	GPS Aided Geo Augmented Navigation
Galileo	Galileo Satellite Navigation System (EU)
GLONASS	Global Navigation Satellite System (Russia)
GNSS	Global Navigation Satellite System
GPS	Global Positioning System
I/O	Input/Output
I2C	Inter-integrated Circuit
IC	Integrated Circuit
IMU	Inertial Measurement Unit
I _{PEAK}	Peak Current
NavIC	Indian Regional Navigation Satellite System
kbps	kilobits per second
LDO	Low-dropout Regulator
LGA	Land Grid Array
LNA	Low-noise Amplifier
MCU	Microcontroller Unit/Microprogrammed Control Unit
MSAS	Multi-functional Satellite Augmentation System (Japan)
MSL	Moisture Sensitivity Levels
NMEA	NMEA (National Marine Electronics Association) 0183 Interface Standard
OC	Open Collector
PCB	Printed Circuit Board
PI	Power Input
PMU	Power Management Unit
PO	Power Output

Abbreviation	Description
ppm	parts per million
PPP	Precise Point Positioning
PQTM	Quectel Proprietary Protocol
PSRR	Power Supply Rejection Ratio
QZSS	Quasi-zenith Satellite System
RF	Radio Frequency
RHCP	Right Hand Circular Polarization
RMS	Root Mean Square
RoHS	Restriction of Hazardous Substances
RTC	Real-time Clock
RTCM	Radio Technical Commission for Maritime Services
RTK	Real-time Kinematic
RXD	Receive Data (Pin)
SAW	Surface Acoustic Wave
SBAS	Satellite-based Augmentation System
SDCM	The System for Differential Corrections and Monitoring
SMD	Surface Mount Device
SMT	Surface Mount Technology
SRAM	Static Random Access Memory
TCXO	Temperature Compensated Crystal Oscillator
T_operating	Operating Temperature
TTF	Time to First Fix
TVS	Transient Voltage Suppressor
TXD	Transmit Data (Pin)
UART	Universal Asynchronous Receiver/Transmitter

Abbreviation	Description
USB	Universal Serial Bus
VCC	Supply Voltage (Pin)
$V_{I\max}$	Maximum Input Voltage
$V_{I\min}$	Minimum Input Voltage
$V_{I\text{nom}}$	Normal Input Voltage
$V_{IH\max}$	High-level Maximum Input Voltage
$V_{IH\min}$	High-level Minimum Input Voltage
$V_{IL\max}$	Low-level Maximum Input Voltage
$V_{IL\min}$	Low-level Minimum Input Voltage
$V_{O\text{nom}}$	Normal Output Voltage
$V_{OL\max}$	Low-level Maximum Output Voltage
$V_{OH\min}$	High-level Minimum Output Voltage
VSWR	Voltage Standing Wave Ratio
WAAS	Wide Area Augmentation System
XTAL	External Crystal Oscillator